

A snake wiggle of reaction time functions to indicate holistic perception

Mario Fifić[†]

Daniel Little[‡]



[†] Grand Valley State University

[‡] The University of Melbourne

46th Annual Meeting of the Society of Mathematical Psychology

August 5, 2013, Potsdam, Germany

The holistic hypothesis: Objects are perceived as whole entities and not as a sum of independent features

Analytic, or feature-based

hypothesis: Objects are perceived as a simple sum of independent features

Signatures of Holistic perception

- Gestalt laws: proximity similarity by inducing perceptual effects (Sarris; Overvliet, Krampe & Wagemans)
- Pop-out effect (Pomerantz; Eidels)
- Part to whole paradigm (Donnelli; Tanaka & Farah; Bierman)
- Garner Task (Kimchi)
- Superiority effects (Pomerantz)
- Thatcher faces illusion: Grotesqueness (Wenger)
- Face inversion (Bartlett, Innes-Ker)
- Unitization (Goldstone, Blaha)
- Scrambled faces vs Normal
- Neural Responses (Peterson, Palmeri)
 - Lightfoot & Shiffrin
- Context effect (Palmer, Kimchi)
- **Super capacity index** (Townsend, Eidels, Blaha)
- **Coactivation signature** (Colonus, Little, Fific, Nosofsky, Townsend; Houpt)

Systems Factorial Technology

SFT

A catalog of mental architectures

Signatures

SIC

A
Serial
Self-terminating

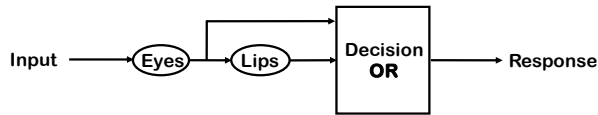

Analytic

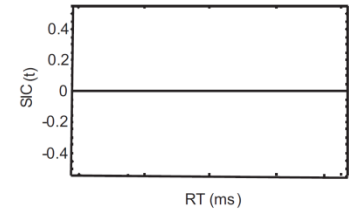

B
Serial
Exhaustive

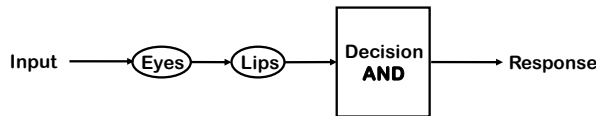

**Analytic/
Holistic**

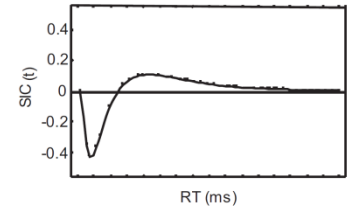

C
Parallel
Self-terminating

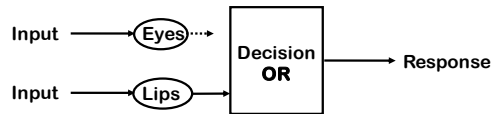

Analytic

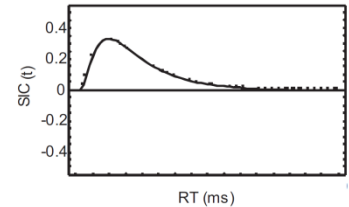

D
Parallel
Exhaustive

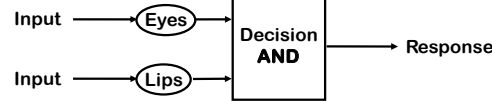

**Analytic/
Holistic**

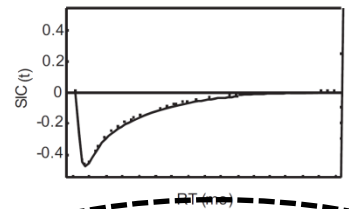

E
Coactive

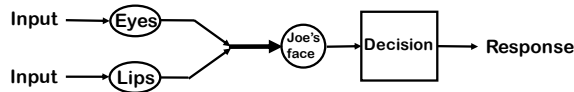

**Strong
Holistic**

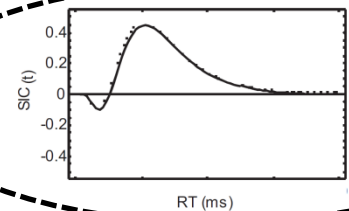

The task

Conjunctive-rule classification “AND”

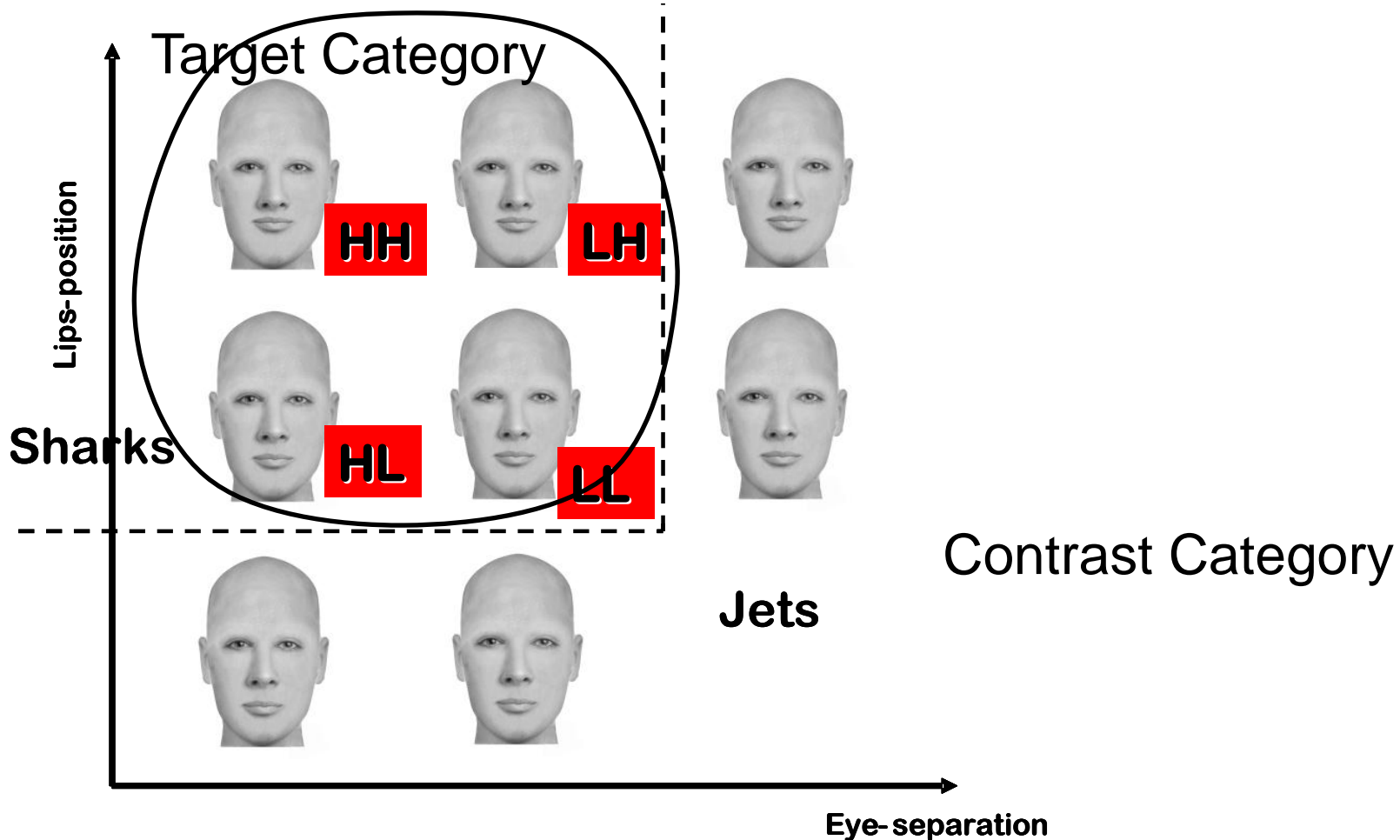

(Fific & Townsend, 2010)

Tutorial: how to calculate the survivor interaction contrast (SIC) function

Conjunctive-rule classification "AND"

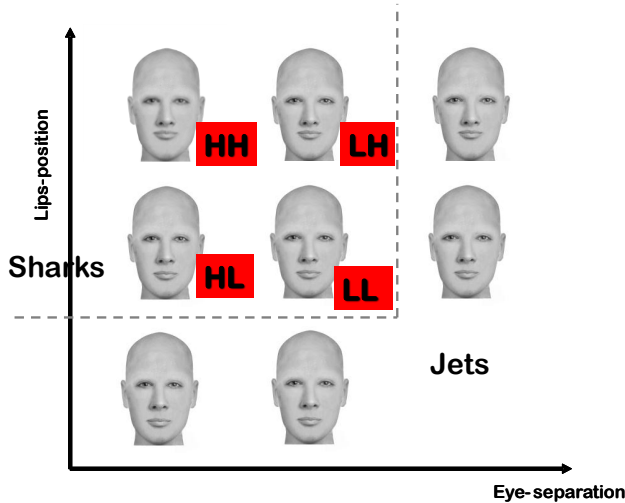

Reaction time histograms

Freq

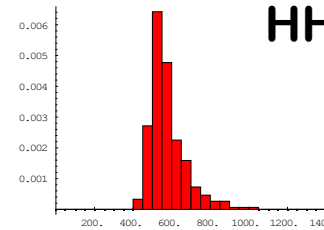

LH

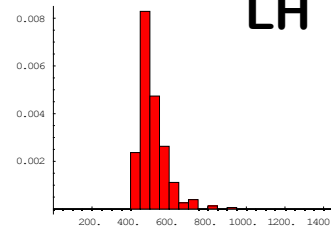

Freq

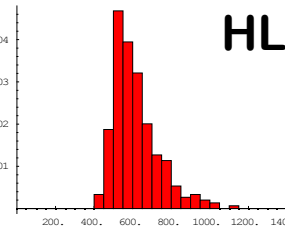

LL

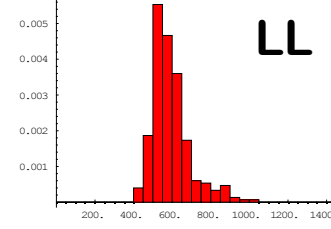

RT(ms)

RT(ms)

Reaction time Survivor functions

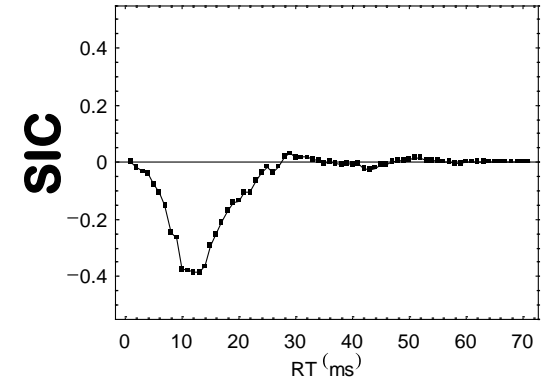
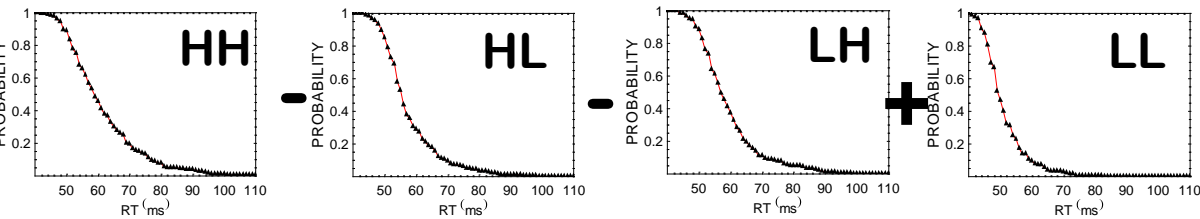

$$SIC(t) = S_{hh}(t) - S_{hl}(t) - (S_{lh}(t) - S_{ll}(t))$$

Part to whole paradigm x SFT

Empirical evidence:

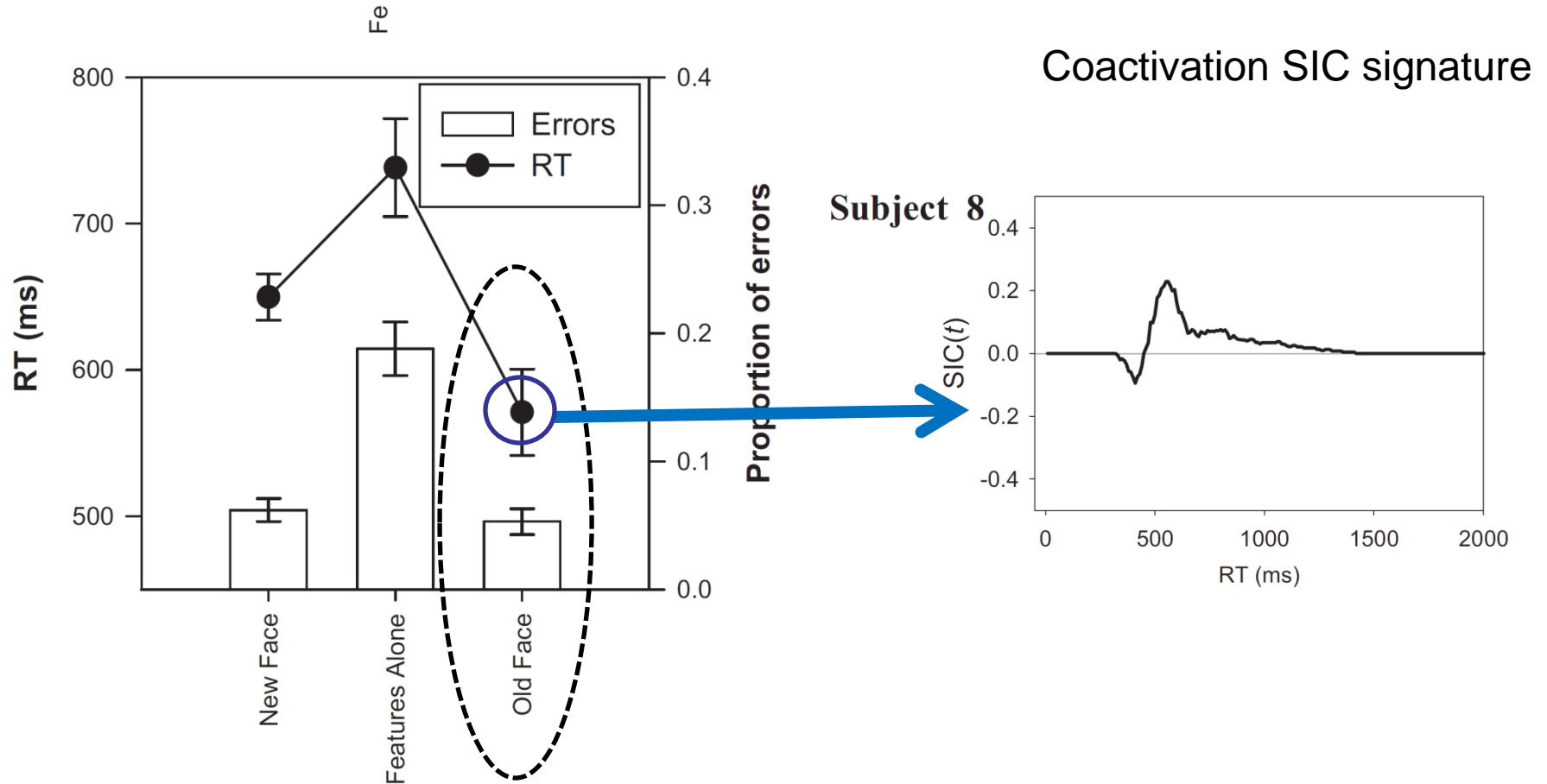

(Fific & Townsend, 2010)

- Can we provide a strong validation of such signature?

New signature of holistic perception

- Dynamical SIC signature

The signature “Snake Wiggle”

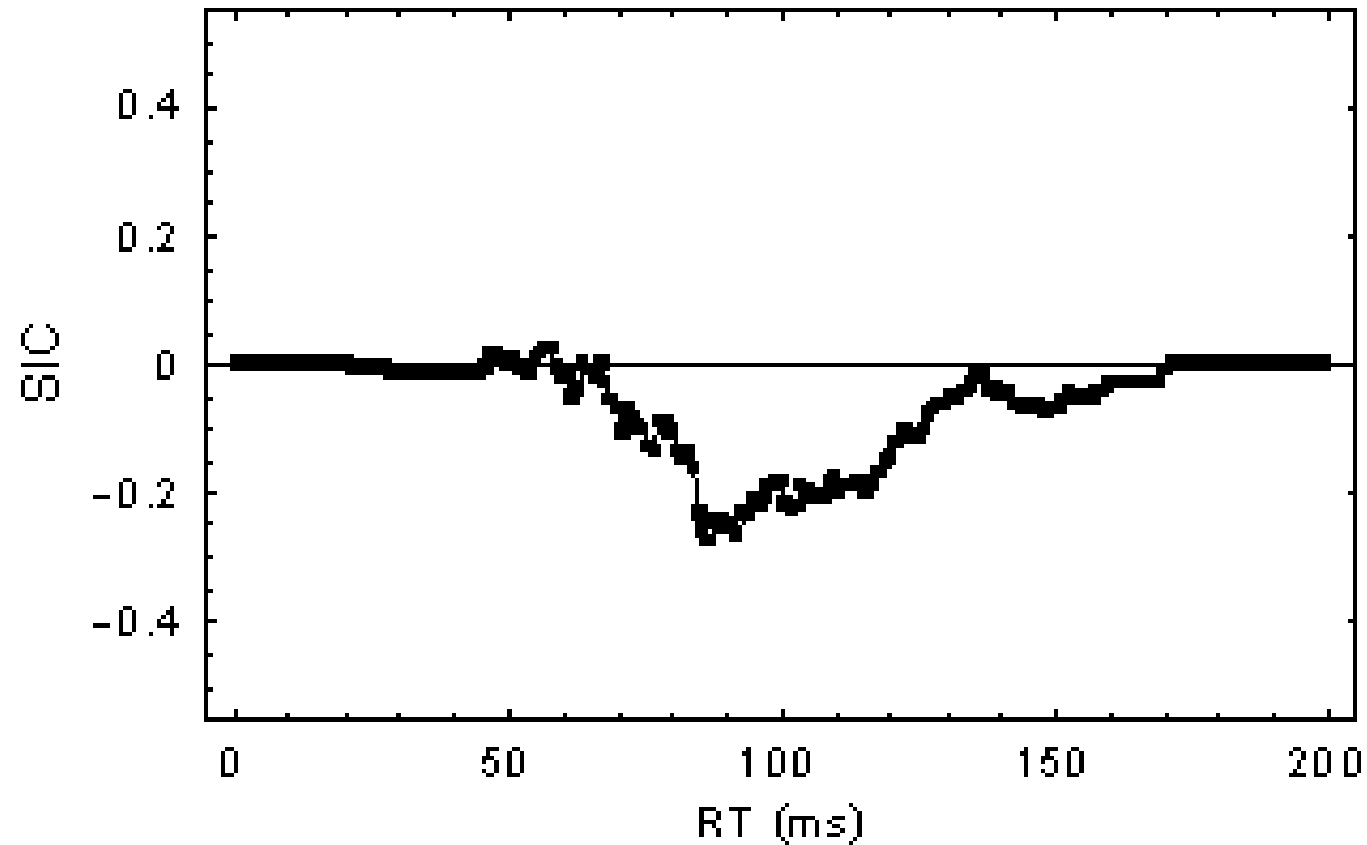

The “Snake Wiggle” signature

Session 1-2

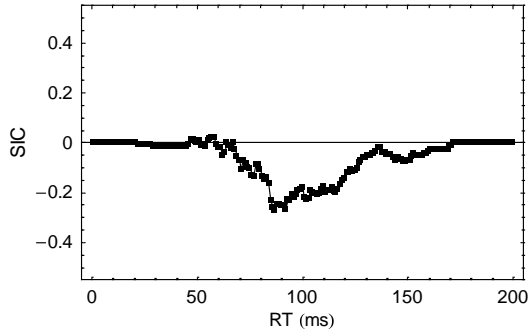

Session 3-4

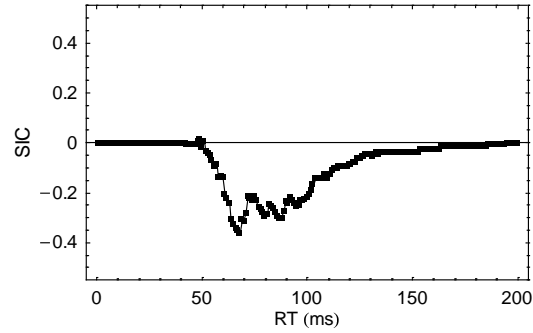

Session 5-6

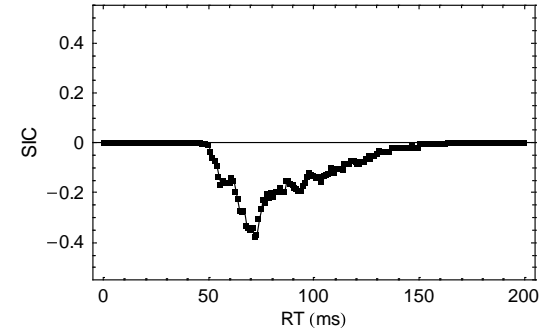

Session 7-8

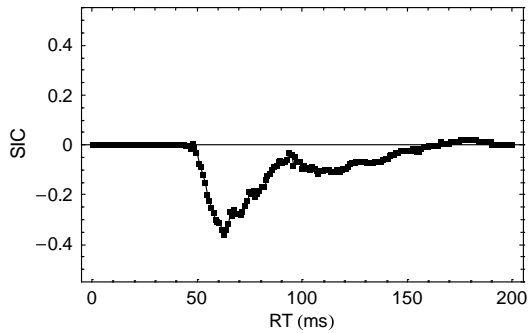

Session 9-10

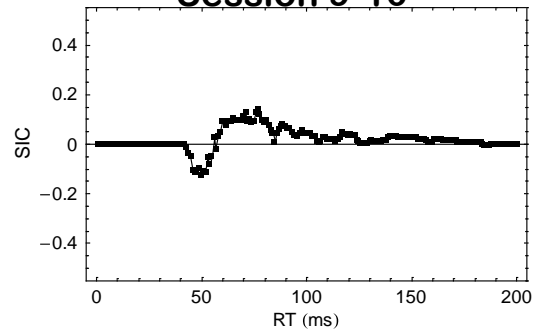

Session 11-12

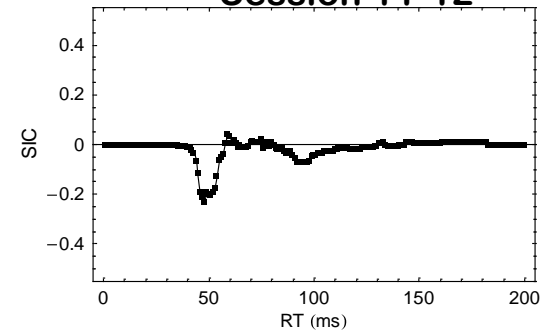

Session 13-14

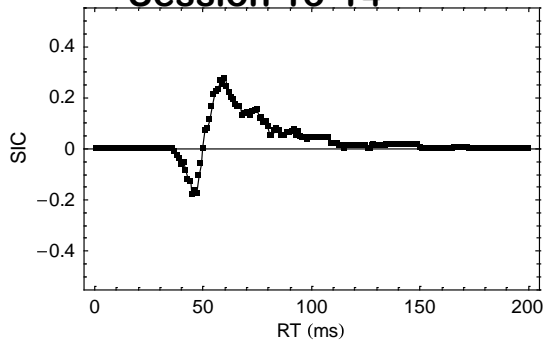

Session 15-16

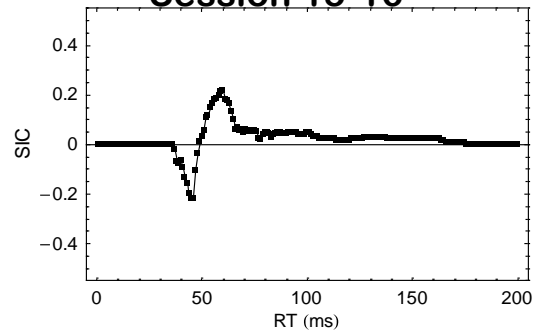

Session 17-18

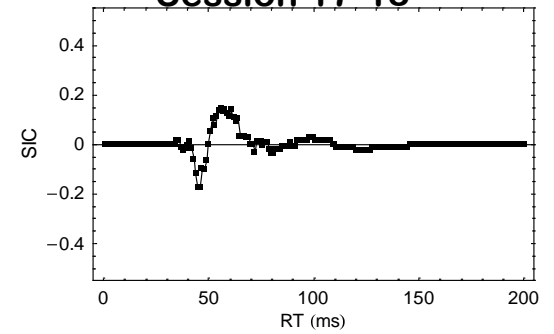

The signature “Snake Wiggle”

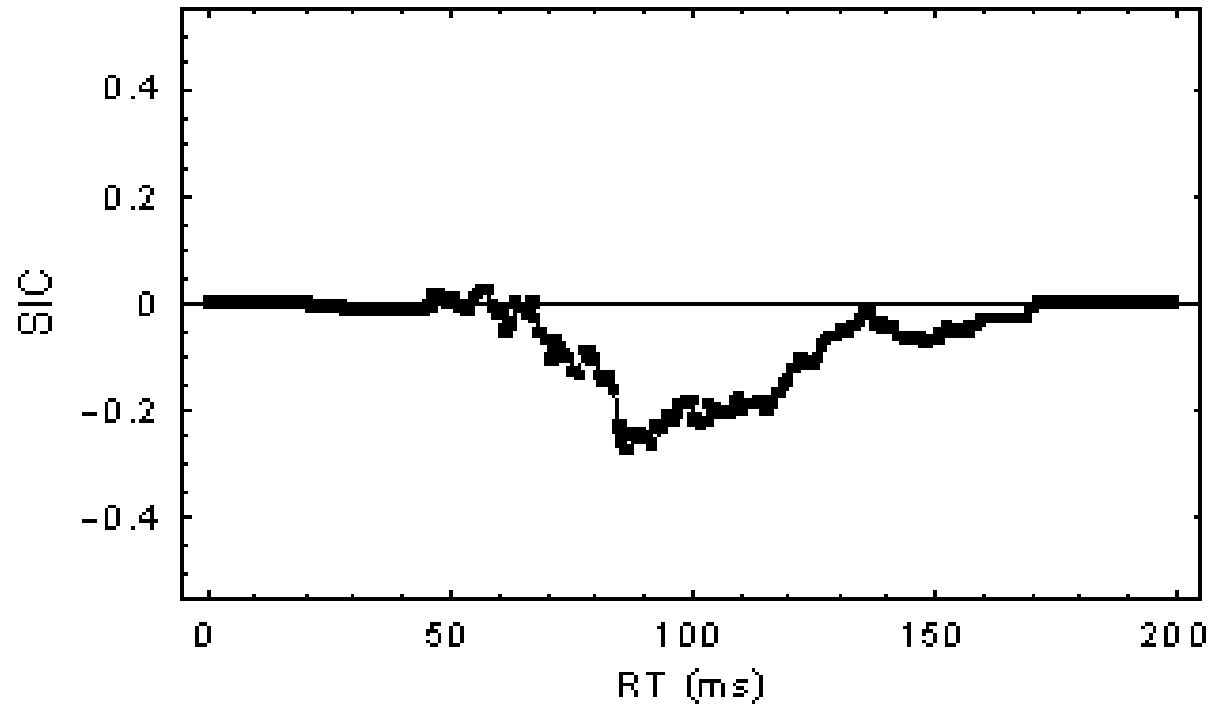

The signature “Snake Wiggle”

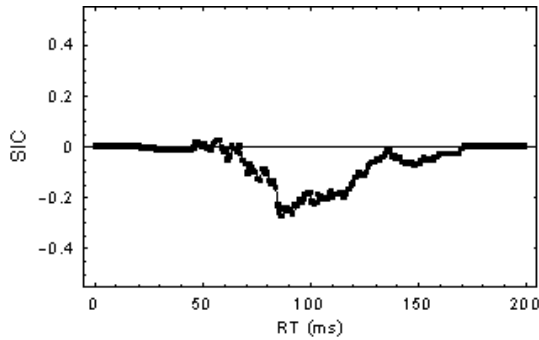

**The total area
under the curve**

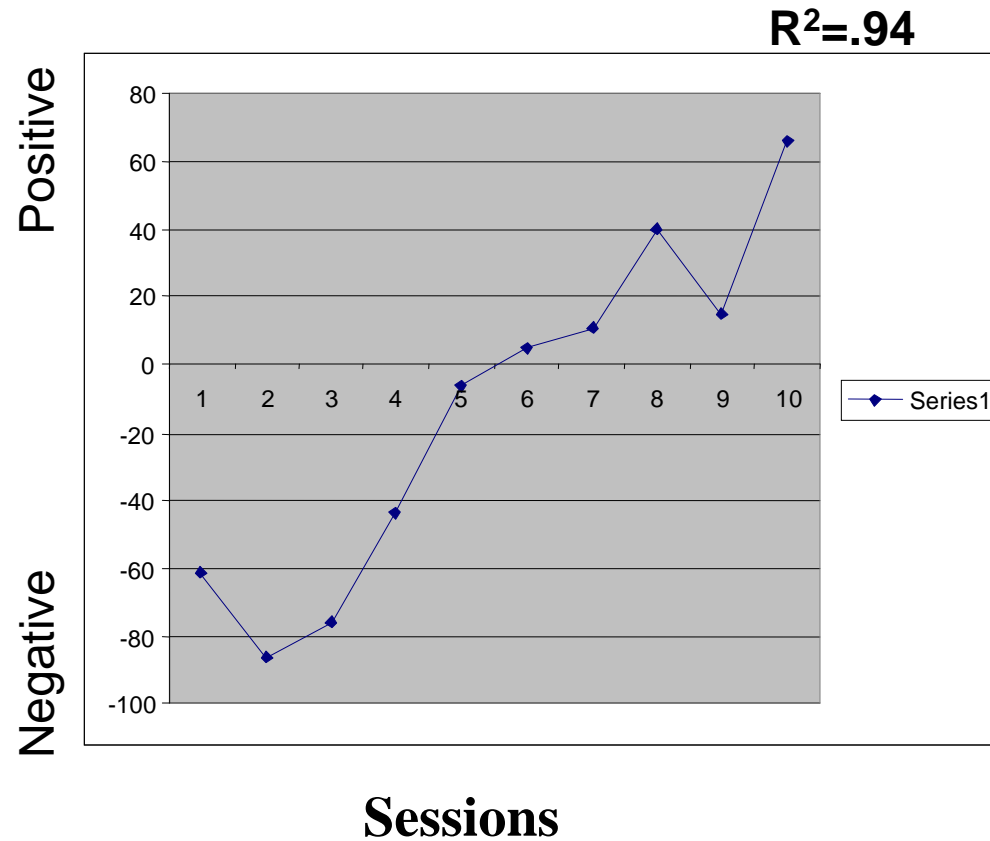

The signature “Snake Wiggle”

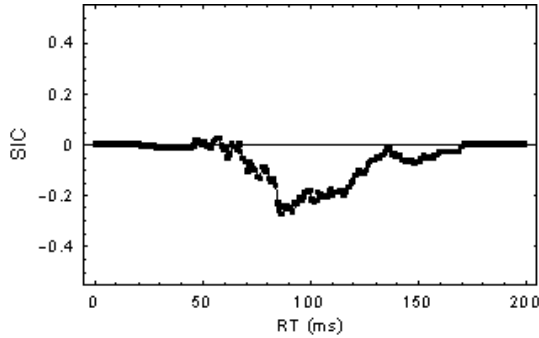

The sum of the area under the curve

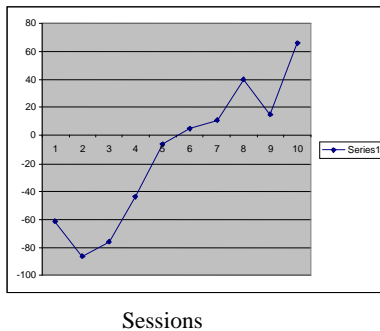

Mean RT trend

Mean RT

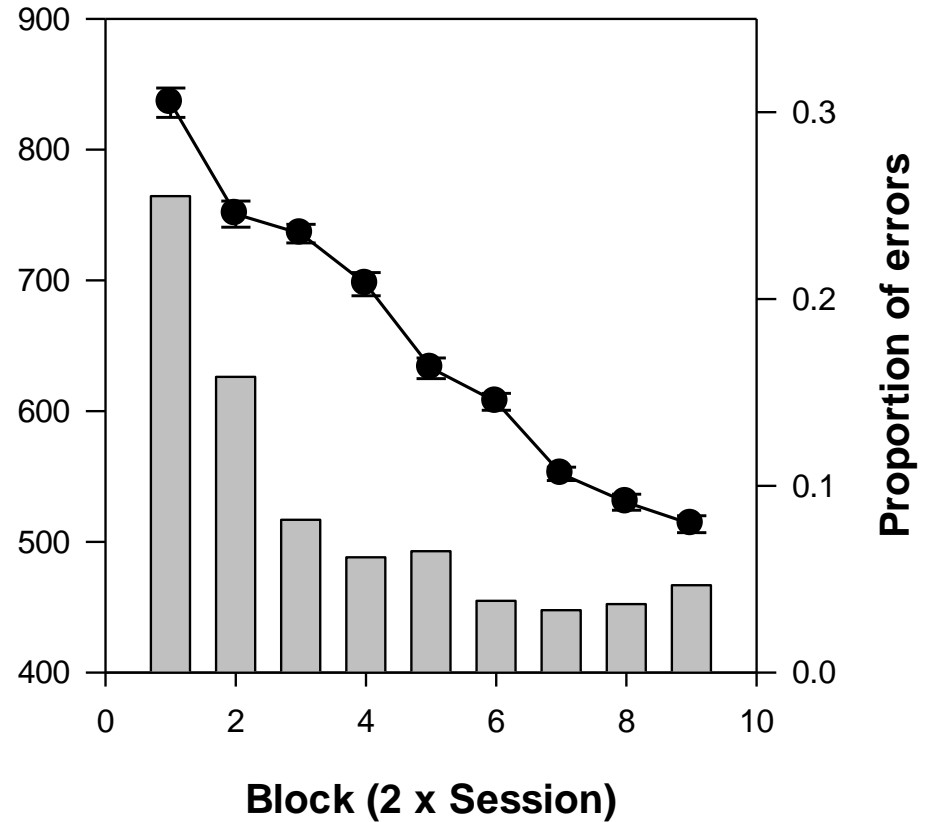

The evidence for “Snake Wiggle”

- **Let’s wiggle:** The SIC function wiggles its way to S-shaped positive function
- **Robustness:** All subjects wiggled
- **Coactivation:** The target signature is Coactive, an indicator of strong holism
- **Performance superiority:** Mean RT decreases, and accuracy improves (superior performance)
- **Introspection:** The verbal reports

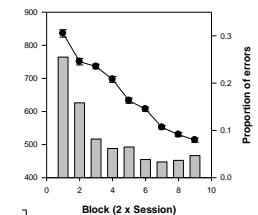
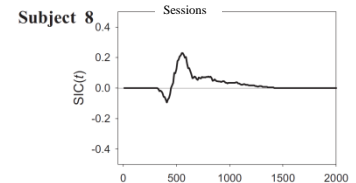
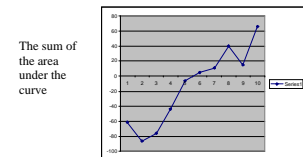
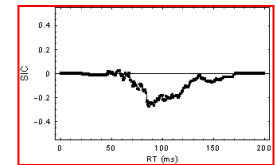

Conclusion

- How strong is the conclusion that a Snake Wiggle signature indicates strong holism?
- Can we make it stronger?

Converging evidence

Conjunctive-rule classification “AND

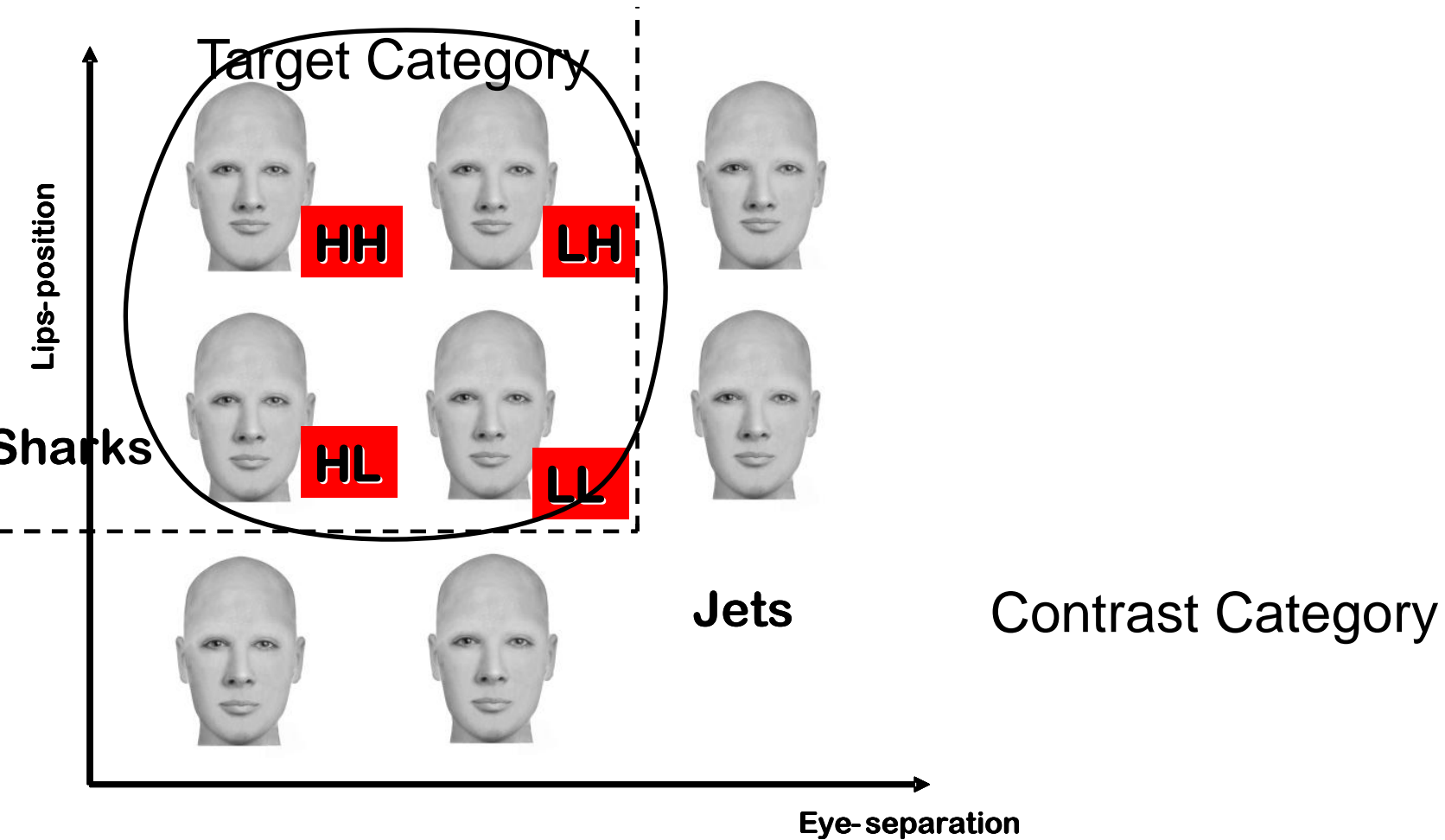

(Fific & Townsend, 2010)

Converging evidence

Conjunctive-rule classification “AND

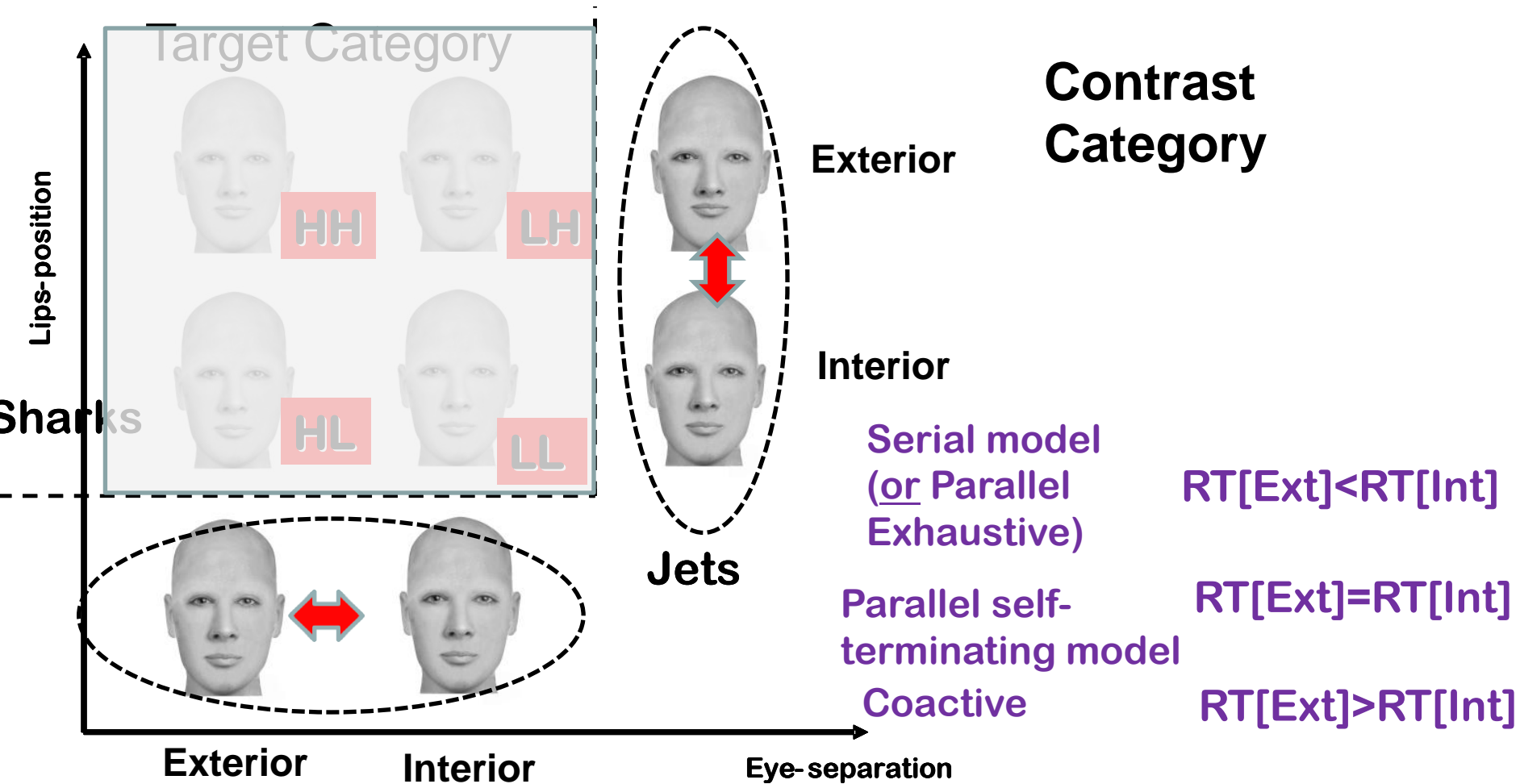

(Fific, Little & Nosofsky, 2010; Psych Review)

Converging evidence

RT[Ext]-RT[Int]

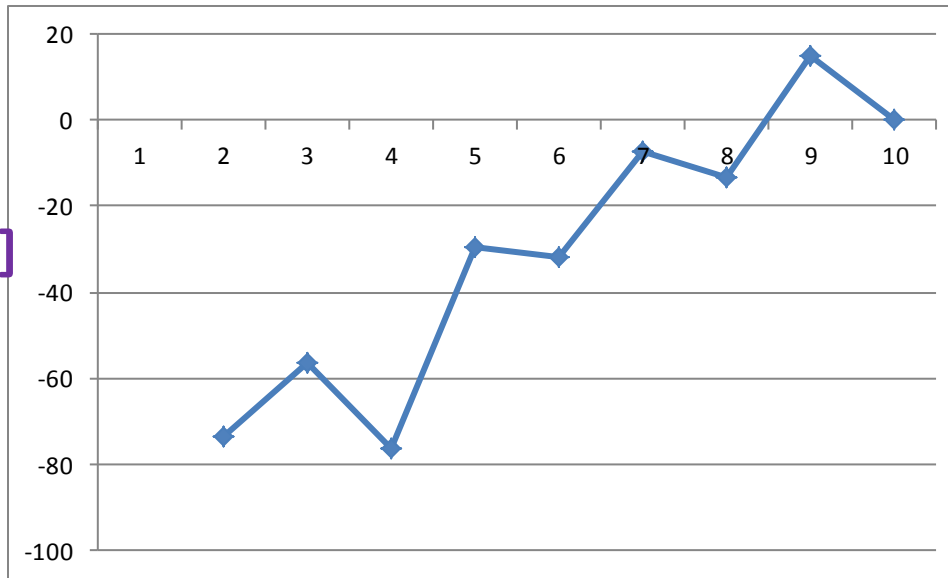

“Coactive”



Snake Wiggle

“Serial or
Parallel Exhaustive”

RT[Ext]-RT[Int]

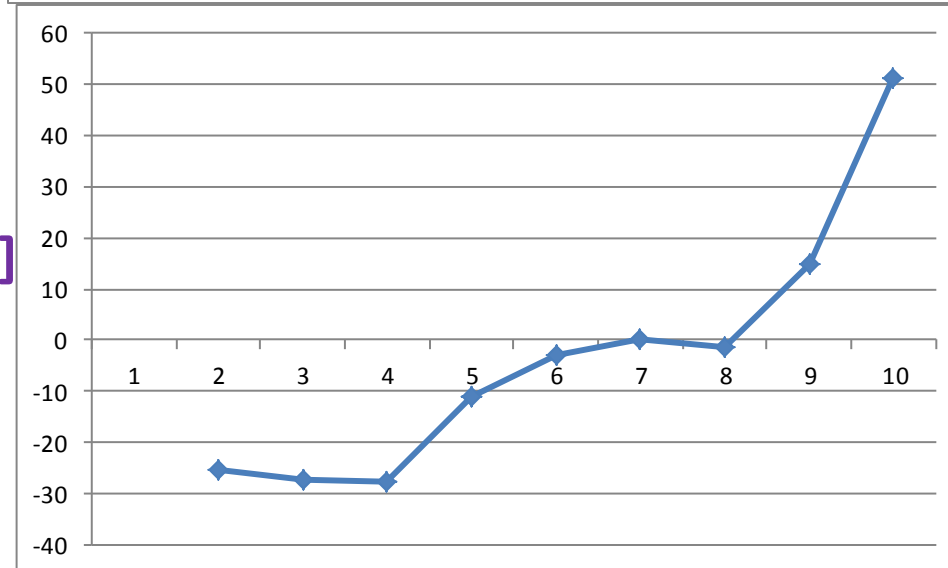

“Coactive”

“Serial or
Parallel Exhaustive”

Cognitive control of Analytic/Holistic Perception?

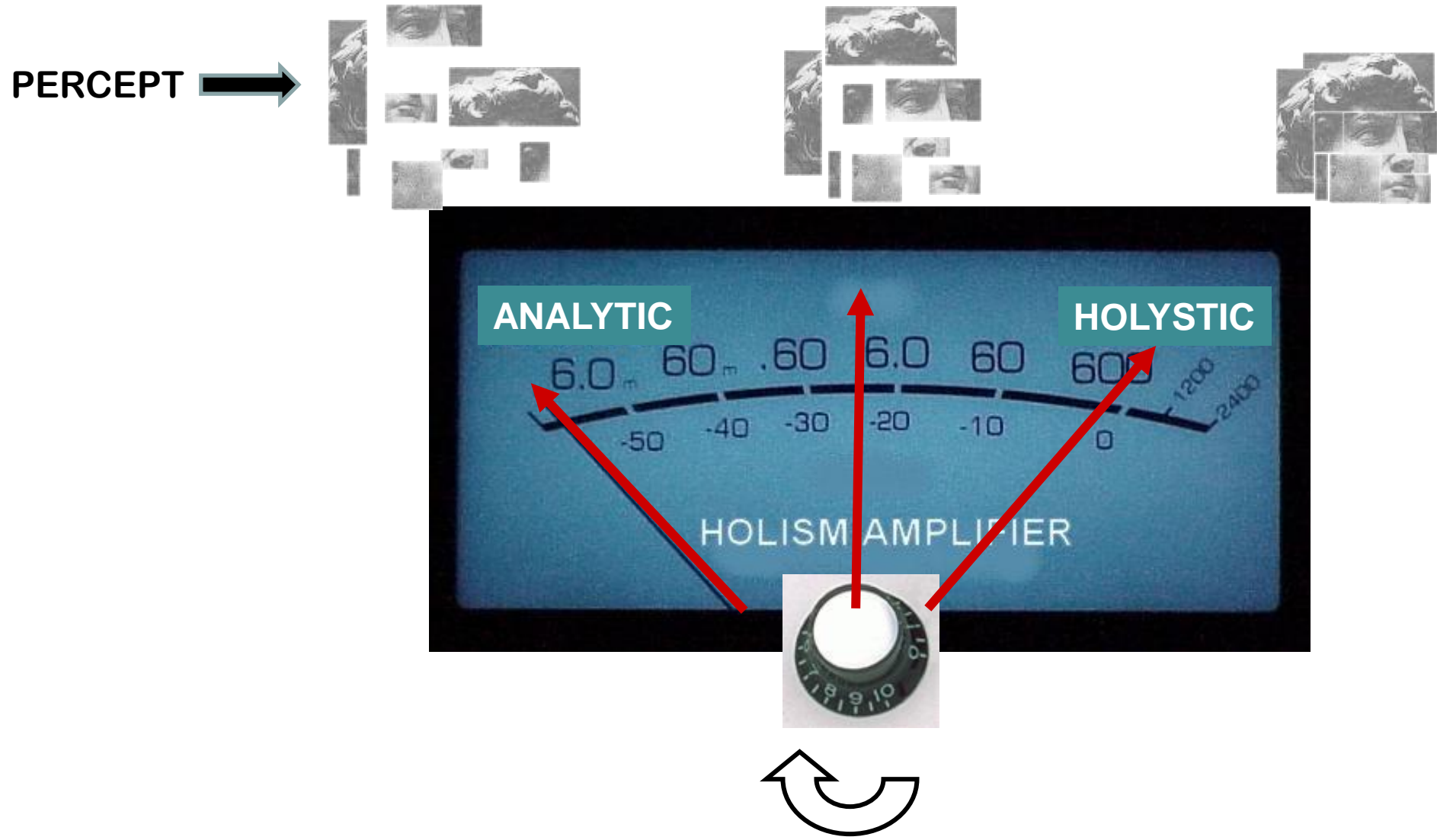

Plausible Model

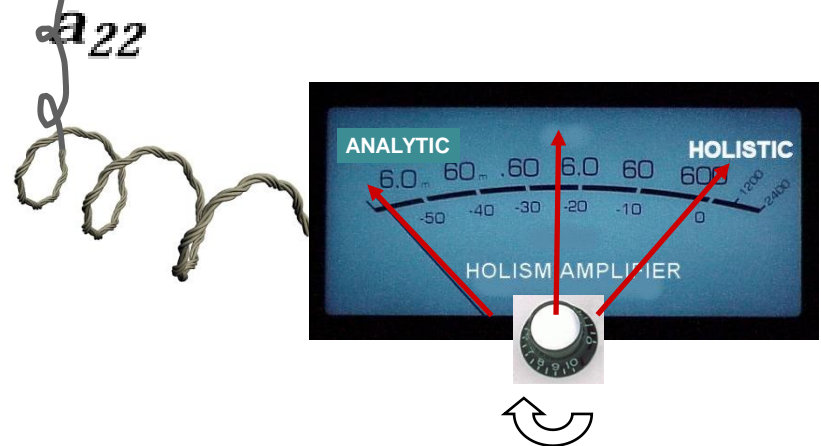
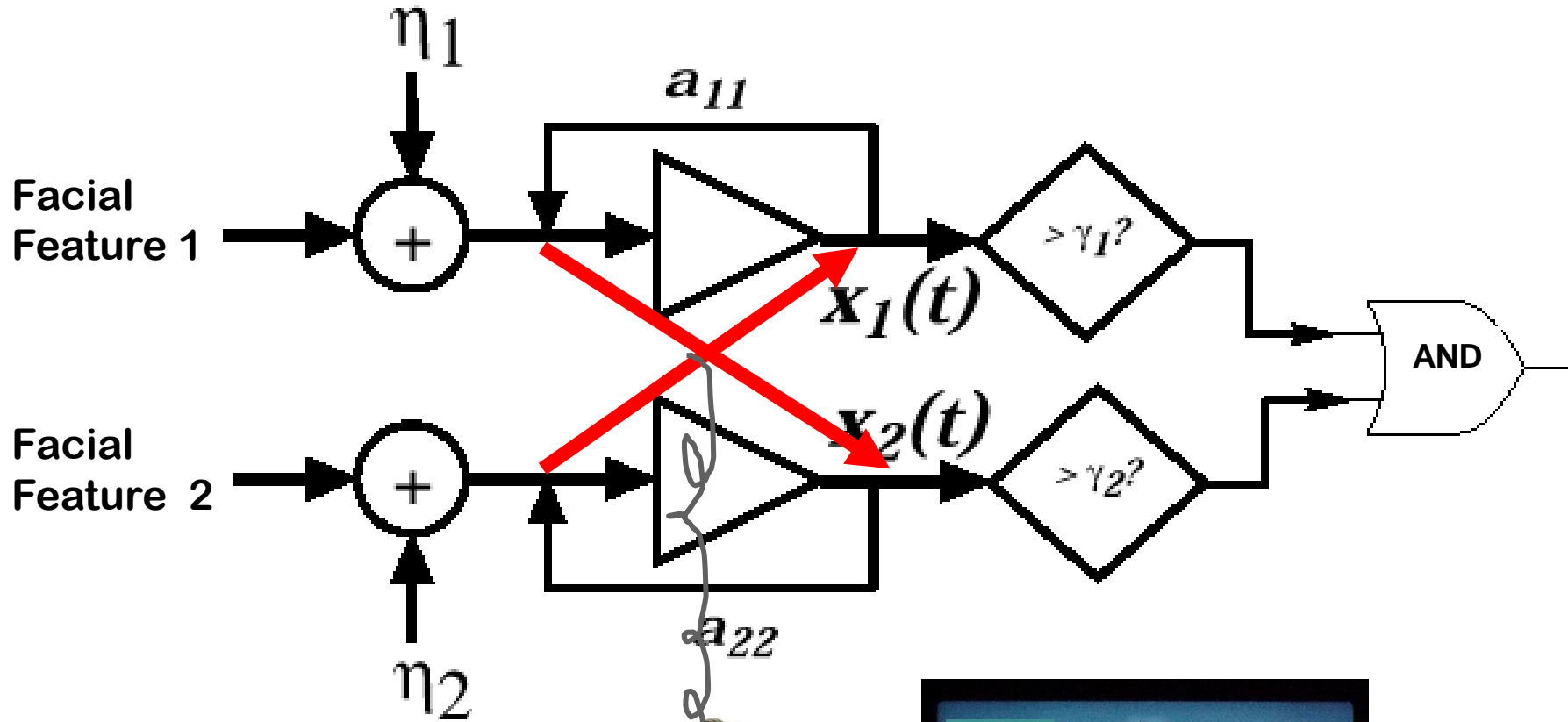

The snake wiggle

- **The snake wiggle is a dynamic signature of holistic perception**
- **The converging evidence from other sources: superiority, robustness and introspection.**
- **The entire stimulus set wiggles.**
- **Plausible trusted models for dynamical evidence accumulation.** (Houpt & Townsend, 2011; Fific & Townsend, 2010; Eidels, Houpt, Altieri & Townsend, 2011)
- **Let's wiggle.**

